

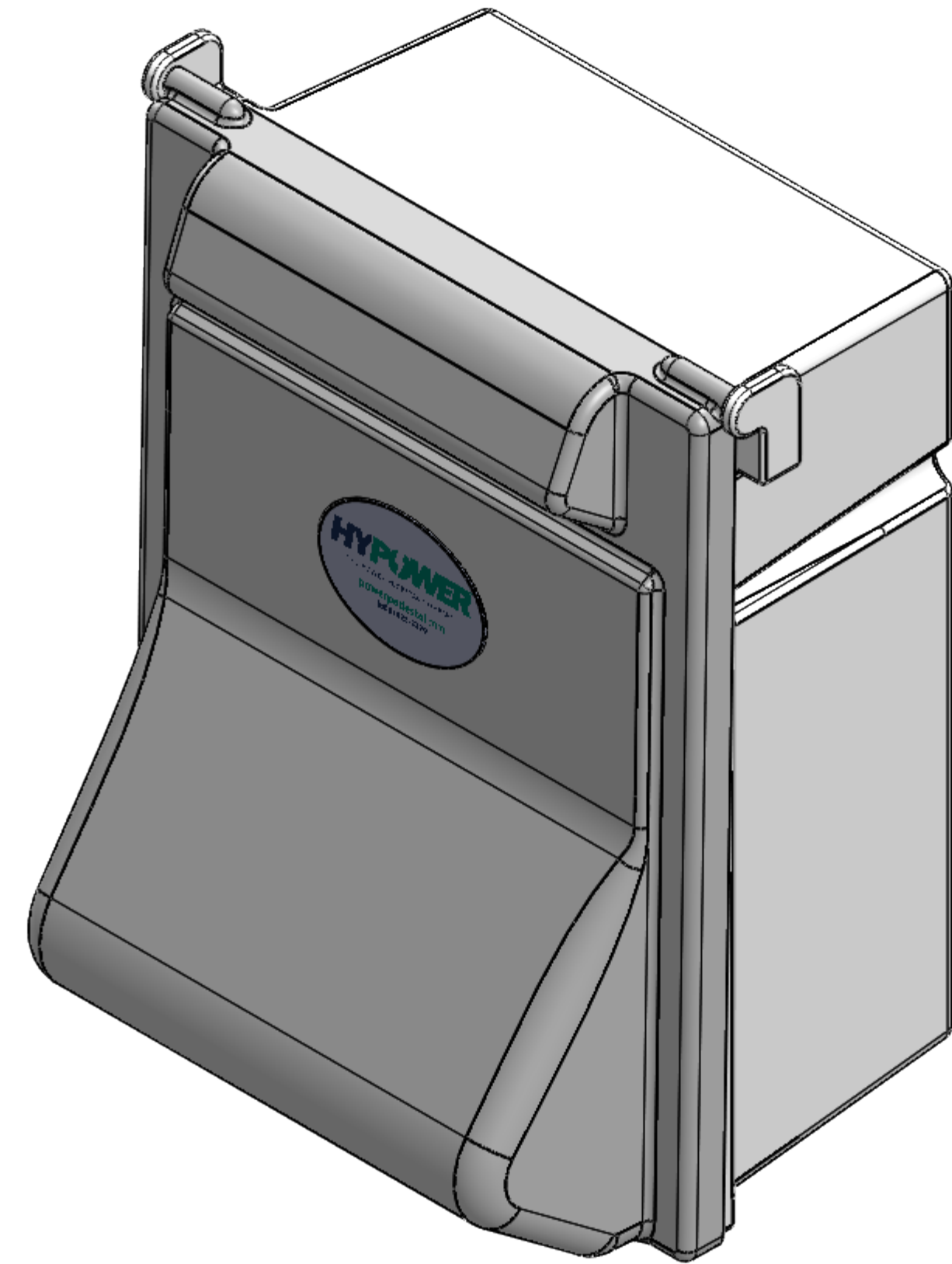

REV.	DATE	DESCRIPTION	ECO #	BY
A	7/27/17	INITIAL RELEASE		TYT

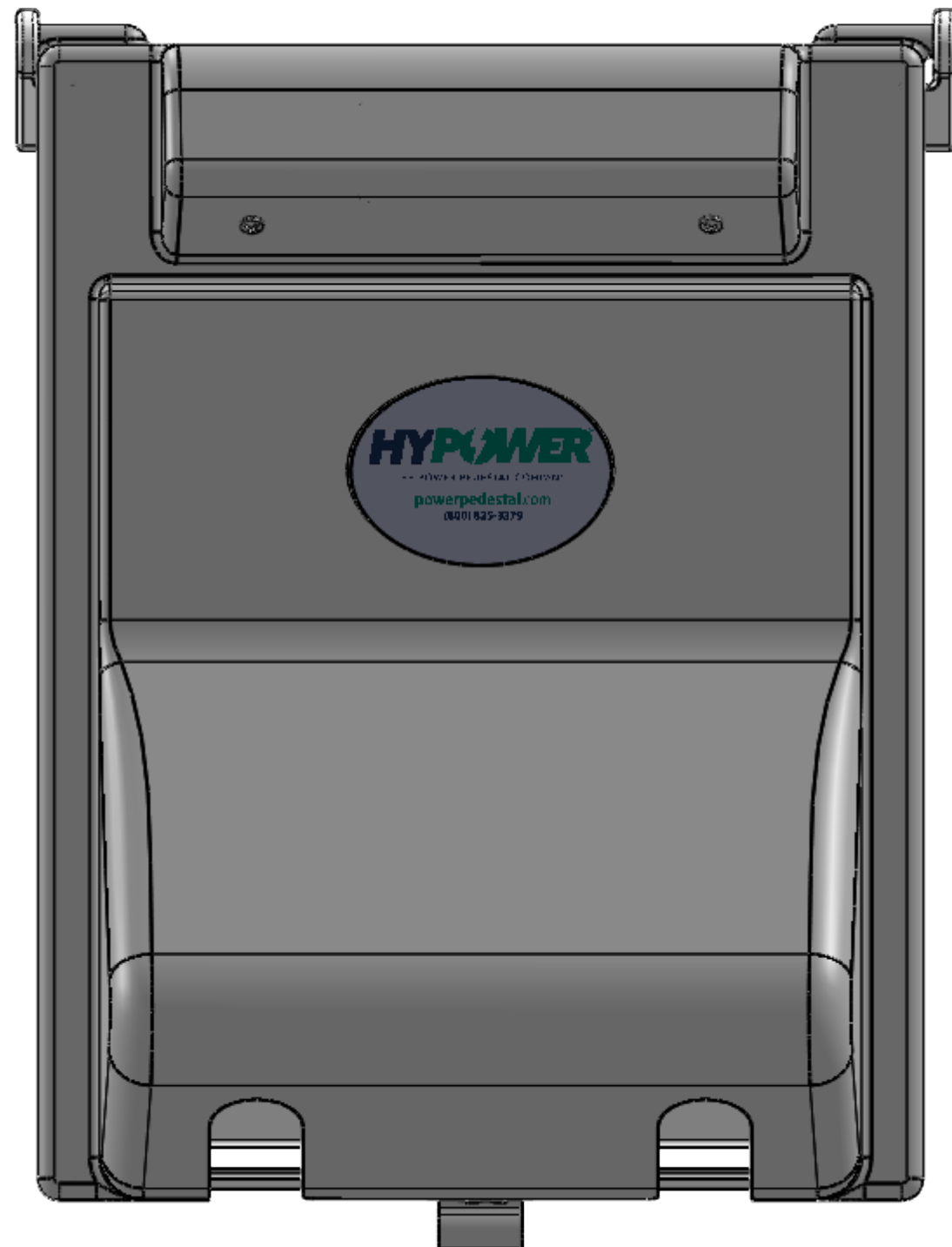
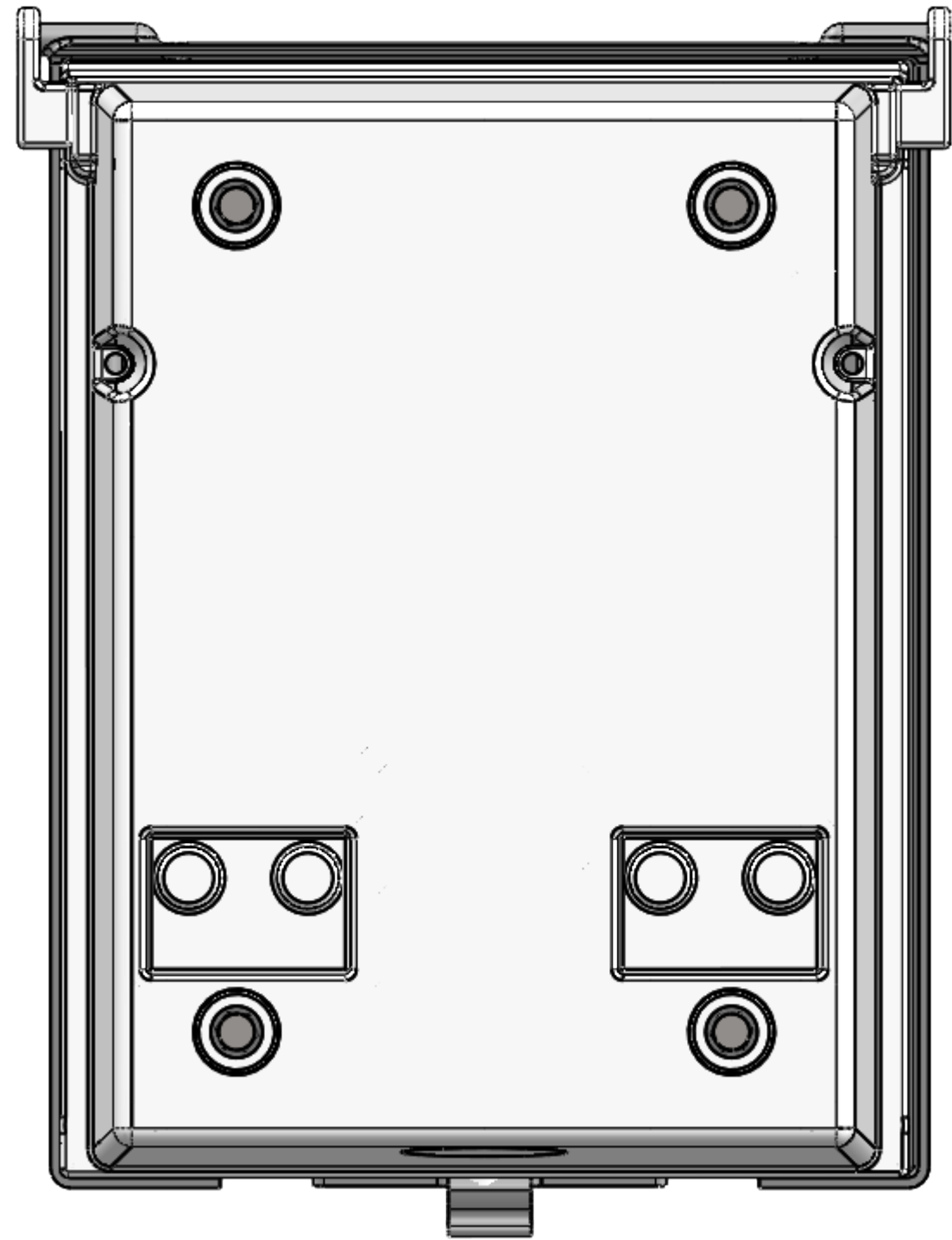

UNLESS OTHERWISE NOTED, ALL DIMENSIONAL TOLERANCES TO BE AS FOLLOWS: X.X = ±.06 ALL ANGLES TO BE ±1° X.XX = ±.05 FRACTIONS = ± 1/32 X.XXX = ±.010	 THE POWER PEDESTAL COMPANY	DWG NO. EM-87(CLEAR)		
		TITLE: EM BOX ASSY - CLEAR LENS		
THIS DRAWING IS THE PROPERTY OF HYDROHOIST MARINE GROUP, INC. AND IS NOT TO BE USED FOR ANY PURPOSE DETRIMENTAL TO ITS INTEREST. WORK TO DIMENSIONS, EVEN WHEN SCALE IS GIVEN, AND REPORT ALL ERRORS.	FINISH: -	DWG. BY: TYT	SCALE: 1:2	REVISION: A
	STATUS:	WEIGHT: 4.31	DATE CREATED: 7/27/2017	

ITEM NO.	PART NUMBER	DESCRIPTION	QTY.
1	12020205	HOUSING BASE ENERGYMATE WHITE	1
2	10020001	LAMP FLUOR. TWIST 4W 28904TC	1
3	72500000	ASSY - EM LIGHT BAR	1
4	12020208	HINGE HOUSING LEFT	1
5	12020207	HINGE HOUSING RIGHT	1
6	15020001	STAB LEFT POWER	1
7	15020002	STAB RIGHT POWER	1
8	15020014	BRACKET - U-CLIP GROUND/NEUTRAL	8
9	15020003	STAB RIGHT HAND SHORT ENERGYMATE	6
10	30080002	WASHER - STAR ID 0.187-OD 0.375	8
11	30000025	SCREW - PAN PHIL 10-32 X .875	8
12	30020002	STUD - BRONZE 1/4 - 20 x 1 3/8	4
13	30080010	WASHER - FLAT BRONZE 1/4	4
14	30010006	NUT - BRONZE 1/4-20	4
15	30000030	SCREW - PAN PHIL 1/4-20 x .75	2
16	30010007	NUT - HEX 10-32	8
17	30000035	SCREW - PAN PHIL 10-32 x .5	2
18	72100000	ASSY - EM LID/CLEAR LENS	1
19	50000012	LABEL - HYPower LOGO 2	1
20	30080008	WASHER - FLAT 1/4 X 0.625	4
21	30080009	WASHER - LOCK 1/4 x 0.437	4
22	30010004	NUT - HEX FINISH 1/4-20	4
23	30000032	SCREW - HEX HEAD 1/4-20 x .875	4

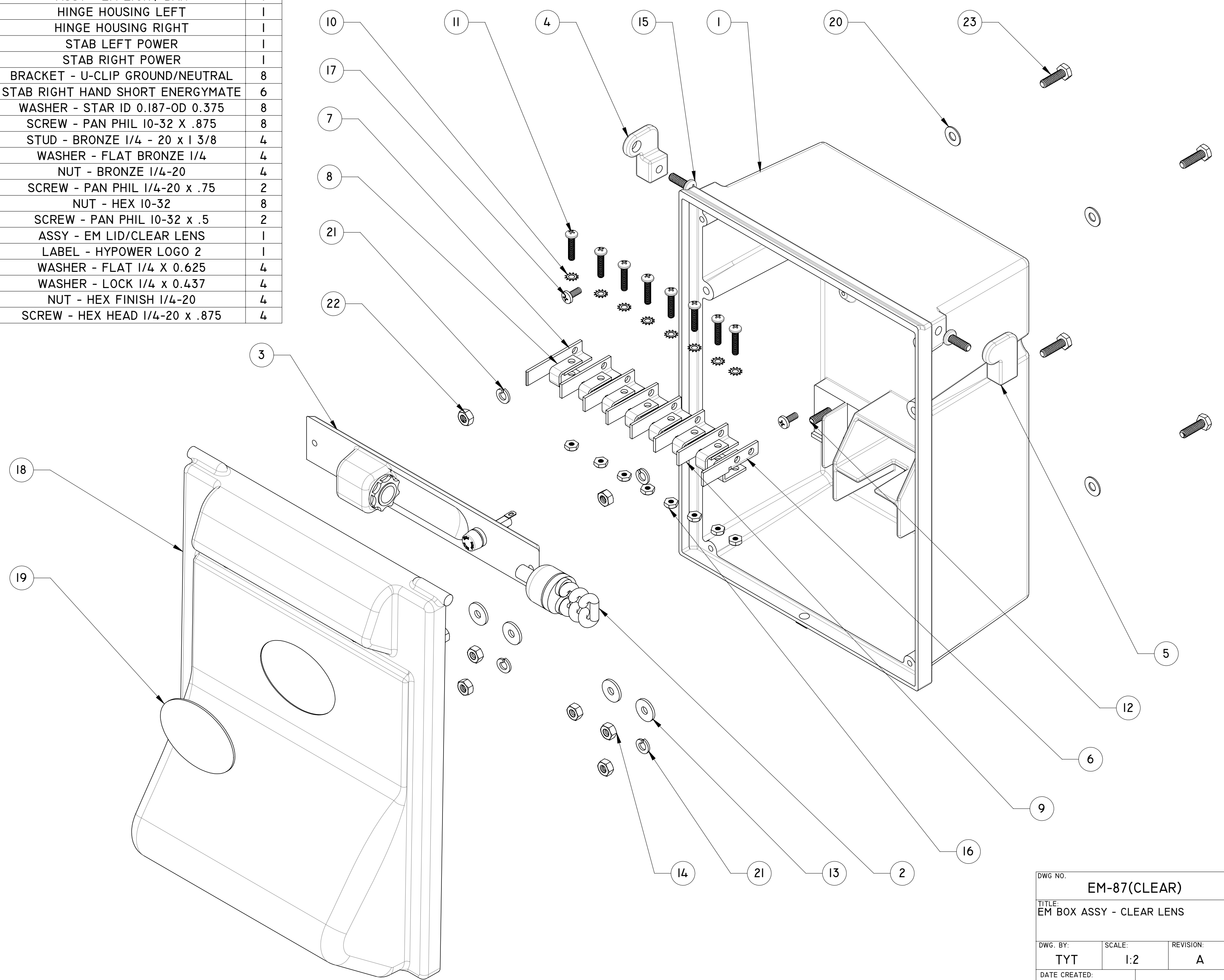

DWG NO.		
EM-87(CLEAR)		
TITLE:		
EM BOX ASSY - CLEAR LENS		
DWG. BY:	SCALE:	REVISION:
TYT	1:2	A
DATE CREATED:		SHEET 2 OF 2
7/27/2017		