

ITEM NO.	PART NUMBER	DESCRIPTION	QTY.
1	MH-2258	WALKBOARD CLAMP	4
2	MH-0590	PILING STRAP BLOCK	8
3	F-0030	1/2"-13 X 3" HEX HEAD BOLT	8
4	F-0005	1/2" SS LOCKWASHER	8
5	F-0006	1/2"-13 SS NUT	8
6	93852A113	1/2" SS FLATWASHER	8

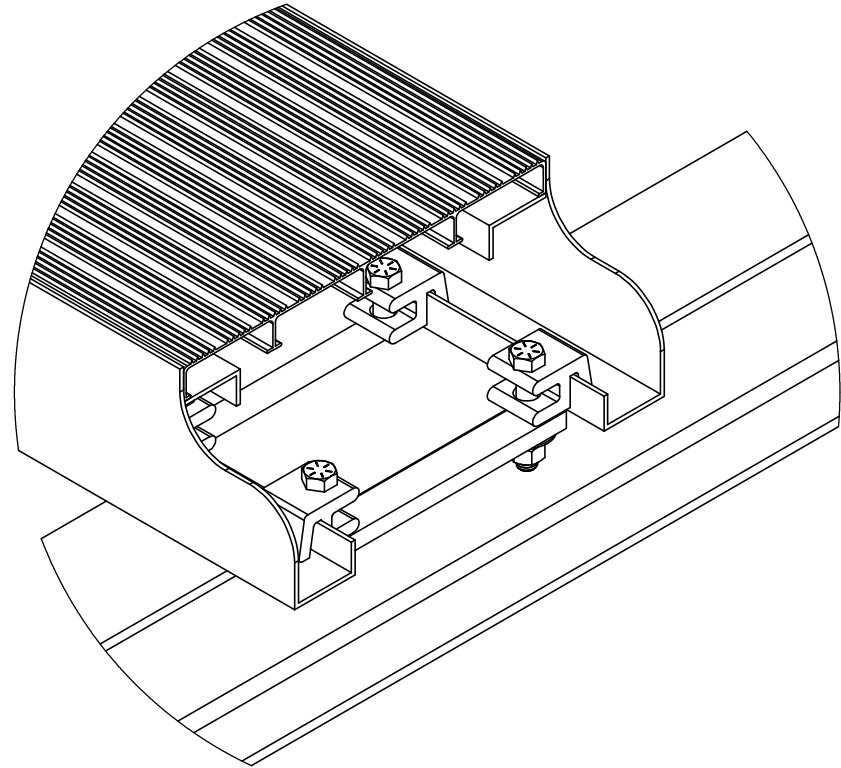
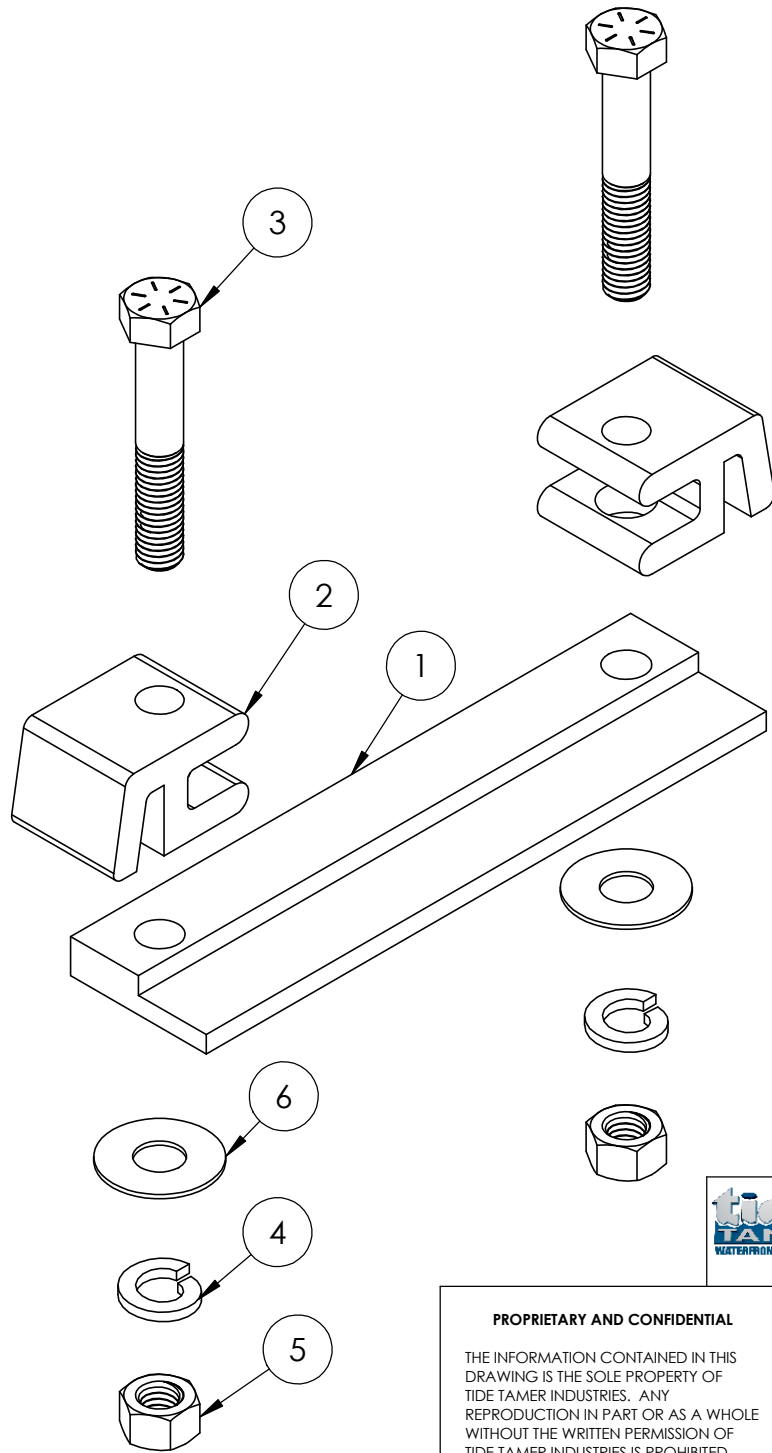

WALKBOARD CUT BACK TO SHOW MOUNT

 PH: 800-325-1116
 FAX: 252-747-4377
 TIDETAMER.COM
 P.O. BOX 1118
 SNOW HILL, NC 28580

PROPRIETARY AND CONFIDENTIAL

THE INFORMATION CONTAINED IN THIS DRAWING IS THE SOLE PROPERTY OF TIDE TAMER INDUSTRIES. ANY REPRODUCTION IN PART OR AS A WHOLE WITHOUT THE WRITTEN PERMISSION OF TIDE TAMER INDUSTRIES IS PROHIBITED.

UNLESS OTHERWISE SPECIFIED:
 DIMENSIONS ARE IN INCHES
 TOLERANCES:
 FRACTIONAL ±
 ANGULAR: MACH ± BEND ±
 TWO PLACE DECIMAL ±
 THREE PLACE DECIMAL ±

DO NOT SCALE DRAWING

	NAME	DATE
DRAWN	ACC	11-9-18
CHECKED		
ENG APPR.		
COMMENTS:		

TITLE: WALKBOARD HARDWARE PACKAGE		
SIZE A	DWG. NO. N/A	REV 1
SCALE: AS NOTED		SHEET 1 OF 1